

COMPACT EXCAVATOR

TB225

takeuchi

From World First to World Leader



Product Features & Specifications

ENGINE

- US EPA Tier 4 Final Diesel
- Mechanical Fuel Injection
- 40 Amp Alternator
- Automatic Fuel Priming System
- Automatic Engine Idle Feature
- Automatic Cold Start Device
- Dual Element Air Cleaner
- Engine Safe Start System

TAKEUCHI FLEET MANAGEMENT

- 2 Year Standard Service
- Minimize Downtime
- Remote Diagnostics
- Utilization Tracking
- Proactive Maintenance
- Control Costs
- Geofencing

UNDERCARRIAGE AND FRAME

- Triple Flange Track Rollers
- Load Sensing Two Speed Travel with Automatic Shift
- Concealed Travel Motor Connections
- Hydraulically Retractable Track Frame (43.3" to 59.1")
- Backfill Blade with Pin-on Extensions
- Wraparound Protective Counterweight
- Integrated Tie Down Points
- 9.8" Rubber Tracks

OPERATOR'S STATION

- ROPS / TOPS / OPG Level 1 Four Post Canopy
- LCD Multifunction Display
- Hour Meter
- Sealed Rocker Switches
- 12 Volt Power Socket
- Adjustable Suspension Seat
- Hand Dial Electronic Throttle Control
- Adjustable Arm Rests
- Foot and Hand Travel Pedals
- 2" Retractable Seat Belt
- Removable, Washable Floor Mat
- Literature Holder

HYDRAULIC AND WORKING EQUIPMENT

- Variable Displacement, Open Center Hydraulics
- Cushioned Boom and Swing Cylinders
- Multifunction Joystick Controls
- Proportional Auxiliary Control with Detent
- Auxiliary Circuit Plumbed to Mid Arm with Shut-off Valves
- Automatic Slew Brake with Integrated Shockless Relief Valve
- Hydraulic Reservoir with Fluid Level Sight Gauge
- Auxiliary Flow Adjustable from Monitor
- Easy Access Pattern Change Valve (ISO or SAE)
- Pilot Pressure Accumulator Valve
- LED Work Lights
- Travel Alarm
- Long Arm with Integrated Thumb Mount
- Boom Swing Function
- Main Boom Cylinder Guard
- Dual Pin Position Bucket (Optional)
- Mechanical Bucket Quick Coupler (Optional)
- Main Pin Hydraulic Thumb (Optional)



Convenient Service and Maintenance Access



Lockable Service Door - Fuel Fill, Hydraulic Tank & Battery

TOUGH, POWERFUL, RELIABLE

Designed to work in confined, demanding applications, the Takeuchi TB225 features many advancements in performance and technology that make it an extremely versatile and productive machine. One of the key features of the TB225 is the hydraulically controlled, variable width undercarriage that can expand to 59.1" wide or retract to 43.3" wide. With the undercarriage fully retracted, the machine is able to maneuver easily through narrow passages to get to the work site. Once at the work site, the undercarriage can be expanded to provide optimum balance and stabilization.

Powering the TB225 is a Yanmar 3TNV80F diesel engine that is U.S. EPA Tier 4 Final compliant and delivers 19.6 horsepower and nearly 50 ft-lb of torque. Matched to this engine is our four pump hydraulic system which provides smooth, coordinated control during simultaneous operation of the boom, arm, bucket, and slew functions without any reduction in work speed and performance.

In order to minimize machine repositioning, the TB225 features a standard long arm that provides greater reach and dig depth while also maintaining excellent bucket breakout and arm crowd forces. To increase speed and efficiency, automatic step-down travel motors will shift to high torque mode when turning, traveling up an incline, or backfilling with the blade. Once the load is reduced the travel motors will automatically return to high speed, low torque mode.

The operator's station provides all day comfort with an adjustable suspension seat, large floor with integrated foot rests, ergonomically designed pilot controls, and adjustable arm rests. The TB225 features advanced controls not available in smaller models, such as electronic throttle control with automatic idle and electronic proportional auxiliary control. In addition, the multifunction display can be used to adjust the auxiliary flow rate and save attachment presets.



Suspension Seat



Multi-Informational Display



Pilot Operated Controls



Retractable Track Frame



Large Flat Floor Area



Well Equipped Operator's Station

OPERATING PERFORMANCE

Operating Weight	4,993 lb	(2,265 kg)
Maximum Bucket Breakout	4,339 lb	(1,968 kg)
Maximum Arm Digging Force	2,877 lb	(1,305 kg)
Arm Length	4' 1.0"	(1,245 mm)
Slew Speed	8.9 min-1	
Traction Force	6,003 lb	(2,723 kg)
Ground Pressure	4.2 psi	(29 kPa)
Max Travel Speed		
Low Range	1.6 mph	(2.5 km/h)
High Range	2.6 mph	(4.2 km/h)

HYDRAULIC SYSTEM

Total Hydraulic Flow	16.6 gpm	(62.8 Lpm)
Auxiliary Flow - Primary Circuit	9.96 gpm	(37.7 Lpm)
Hydraulic System Pressure	3,045 psi	(21.0 MPa)

ENGINE

Model	Yanmar / 3TNV80F	
Displacement	77.3 cu in	(1,267 cc)
Horsepower @ 2,400 rpm	19.6 hp	(14.6 kW)
Max Torque @ 1,800 rpm	49.7 ft-lb	(67.4 Nm)
Alternator	12 V - 0.40 kW	
Battery (IEC 60095-1)	12 V - 45.0 A·h	

FLUID CAPACITY

Engine Lubrication	3.6 qt	(3.4 L)
Cooling System	4.2 qt	(4.0 L)
Fuel Tank Capacity	8.1 gal	(30.5 L)
Fuel Consumption (65% of Full Load)	.80 gal/hr	(3.03 L)
Hydraulic Reservoir Capacity	6.87 gal	(26.0 L)
Hydraulic System Capacity	11.9 gal	(45.0 L)



LED Work Light Package

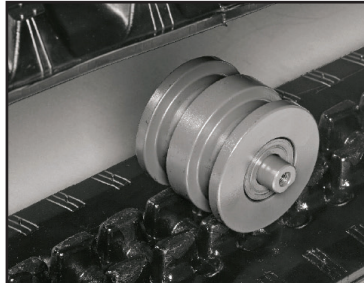

Triple Flange Track Rollers





Main Boom Cylinder Guard



Wraparound Counterweight

TB225 Lifting Capacities at Ground Level*

Lift Point Radius from Rotation Axis	6.6' (2,011 mm)		11.86' (3,614 mm)	
 Lifting Capacities Over Front, Blade Down	2,952 lb	(1,339 kg)	1,369 lb	(620 kg)
 Lifting Capacities Over Side	1,651 lb	(748 kg)	778 lb	(352 kg)

* Ratings based on ISO10567 and do not exceed 87% of hydraulic lift or 75% of tipping load.

ATTACHMENTS

Takeuchi now offers attachments for all of your Takeuchi equipment. See your authorized Takeuchi dealer for additional information and attachment options.

TB225 Compact Excavator

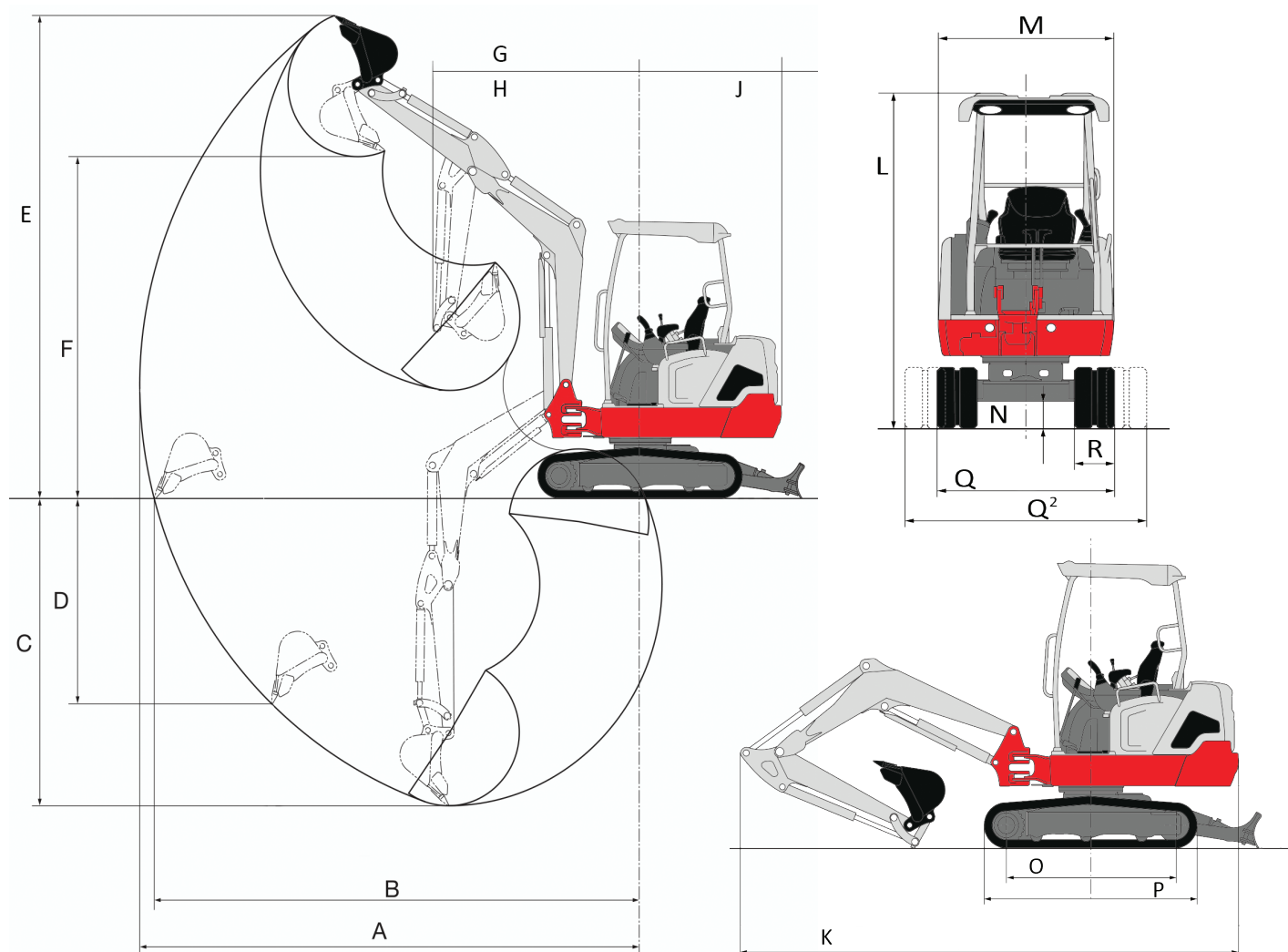

MACHINE DIMENSIONS

A	Maximum Reach	14' 4.2"	(4,375 mm)
B	Maximum Reach at Ground Level	13' 11.3"	(4,250 mm)
C	Maximum Digging Depth	8' 5.5"	(2,580 mm)
D	Maximum Vertical Digging Depth	6' 10.7"	(2,100 mm)
E	Maximum Height of Cutting Edge	13' 3.8"	(4,060 mm)
F	Maximum Dumping Height	9' 5.2"	(2,875 mm)
G	Front Swing Radius	6' 0.0"	(1,830 mm)
H	Front Swing Radius with Boom Offset	4' 10.4"	(1,485 mm)
J	Slew Radius	4' 0.8"	(1,240 mm)
K	Overall Length	13' 8.5"	(4,180 mm)
L	Overall Height	7' 8.8"	(2,355 mm)
M	Upper Structure Overall Width	3' 7.3"	(1,100 mm)
N	Ground Clearance	7.5"	(190 mm)
O	Track Ground Contact Length	4' 7.7"	(1,415 mm)
P	Crawler Overall Length	5' 10.4"	(1,790 mm)
Q	Crawler Retracted	3' 7.3"	(1,100 mm)
Q ₂	Crawler Overall Width	4' 11.0"	(1,500 mm)
R	Crawler Shoe Width	9.8"	(250 mm)



2 YEAR
2,000 HOUR
FULL MACHINE
WARRANTY



© 2021 Takeuchi Manufacturing (U.S.), Ltd. All Rights Reserved. Printed in the U.S.A. In accordance with our established policy of continued improvement, specifications and features are subject to change without notice. Pictures may show options other than standard equipment.

FORM: TB225 Compact Excavator Spec Sheet - Mar. 2021

TAKEUCHI™
 From World First to World Leader